



# Round Container RC

Reusable stainless steel container solutions  
for liquids

# Round Container RC

## Design features

### Tank material

Stainless steel 1.4301 / 1.4404 / 1.4571

### Wall thicknesses

2.0 mm or 2.5 mm for the top, shell and bottom

### Manhole

DN 400 or DN 457 in the top, with screwed cover and eyebolts or tension ring

### Seals

According to customer requirements and/or application

### Transport frame

Galvanised or stainless steel, sprayed on request (stackable, suitable for handling by crane and all other pallet lifting equipment)

### Equipment

- Safety-valve (pressure relief at 0.65 bar at the latest) and aeration vents in the top
- Outlet with ball-valve or butterfly-valve and either a tanker coupling, camlock coupling or sealing cap
- Stacking frame, stackable at least 5 high



- Standard IBC
- Heated containers
- Process containers
- Special containers in stainless steel
- Container accessories/spare parts

**SCHÄFER WERKE GMBH**  
Pfannenbergr. 1 · D-57290 Neunkirchen  
Phone +49 (0) 2735/787-578  
Fax +49 (0) 2735/787-580  
info@schaefer-container-systems.de  
www.schaefer-container-systems.de

### Application

Chemicals/petrochemicals, waste disposal/recycling, food industry, paints/lacquers, plant construction

### Approval

As a metal intermediate bulk container IBC, code 31A, for land and sea transport of hazardous liquid materials of packaging groups II and III, max. density of the filling goods is 1.9 kg/l / 1.8 kg/l. The design fulfils the test requirements for IBCs for the transport of dangerous materials contained in the following international standards:

- European Agreement on the International Carriage of Dangerous Goods by Road (ADR)
- Regulations for the International Carriage of Dangerous Goods by Rail (RID)
- International Maritime Dangerous Goods Code (IMDG Code)
- United Nations Recommendations on the transport of dangerous goods (UN)

### Special designs

- Agitating device

### Dimensions

Basic size 1200 x 1100 mm

Type	Volumes (litres)	Height (mm)
RC 500	497	1100
RC 800	797	1440
RC 1000	1021	1670

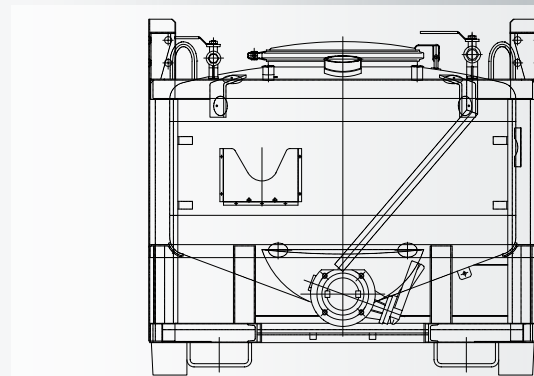

max. density of the filling goods 1.8 kg/l